

## GTMR 346 B

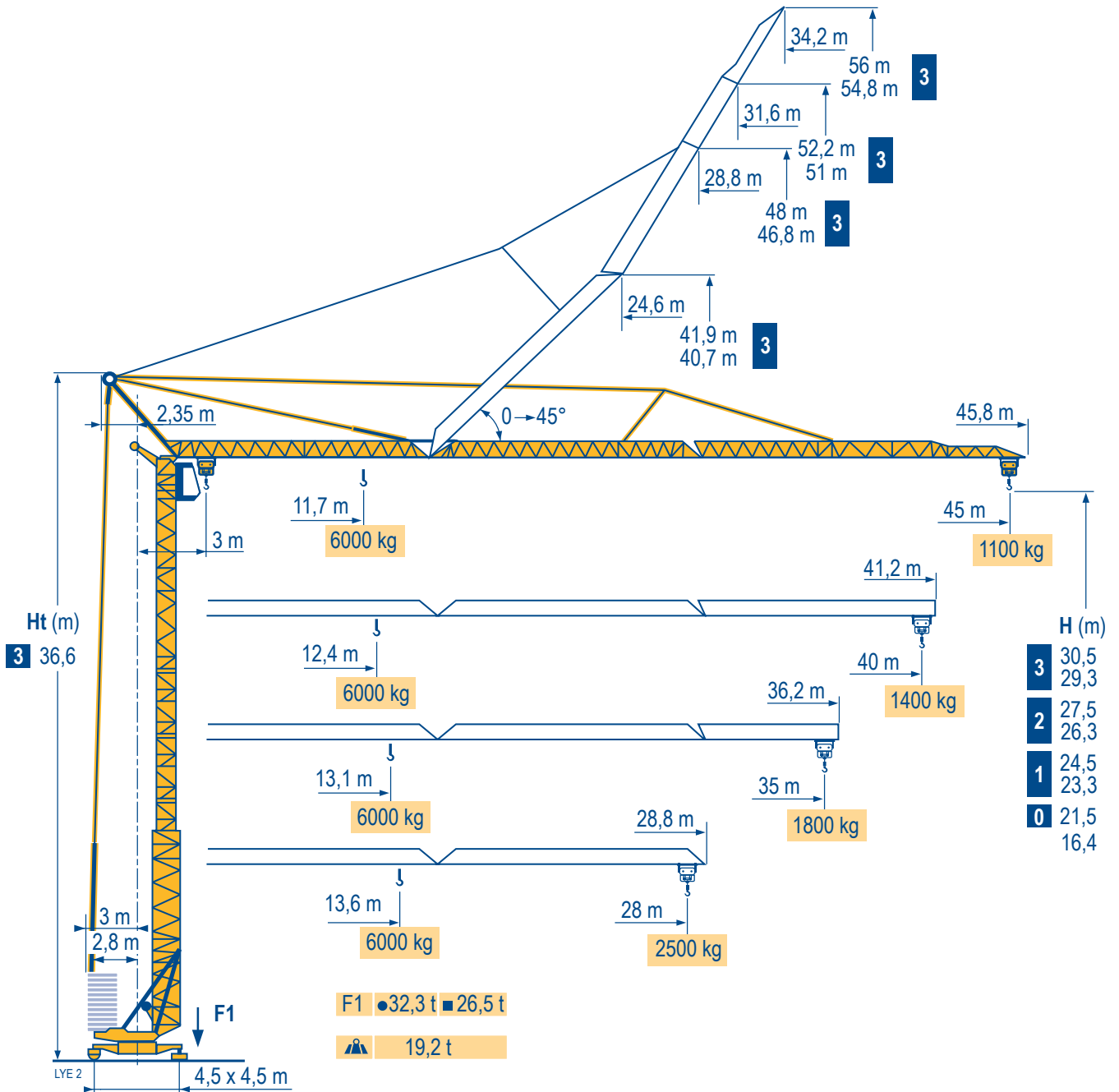

<b>Courbes de charges</b>	45 m	3 ▶	11,7	13	15	17	20	23	25	27	30	33	35	37	40	43	45	m
			6000	5265	4400	3770	3090	2600	2345	2130	1865	1655	1535	1430	1290	1170	1100	kg
<b>Lastkurven</b>																		
<b>Load diagrams</b>																		
<b>Curvas de cargas</b>	40 m	3 ▶	12,4	13	15	17	20	23	25	27	30	33	35	37	40		m	
			6000	5650	4730	4055	3325	2800	2530	2300	2020	1790	1660	1550	1400		kg	
<b>Curve di carico</b>																		
<b>Curva de cargas</b>																		
LVE 1	35 m	3 ▶		13,1	15	17	20	23	25	27	30	33	35				m	
				6000	5080	4360	3580	3020	2725	2480	2180	1940	1800				kg	
	28 m	3 ▶		13,6	15	17	20	23	25	27	28						m	
				6000	5330	4580	3760	3175	2870	2615	2500						kg	

Flèche relevée  
Ausleger in Steilstellung  
Luffing jib  
Flecha izada  
Braccio impennato  
Lança inclinada

LVE 1

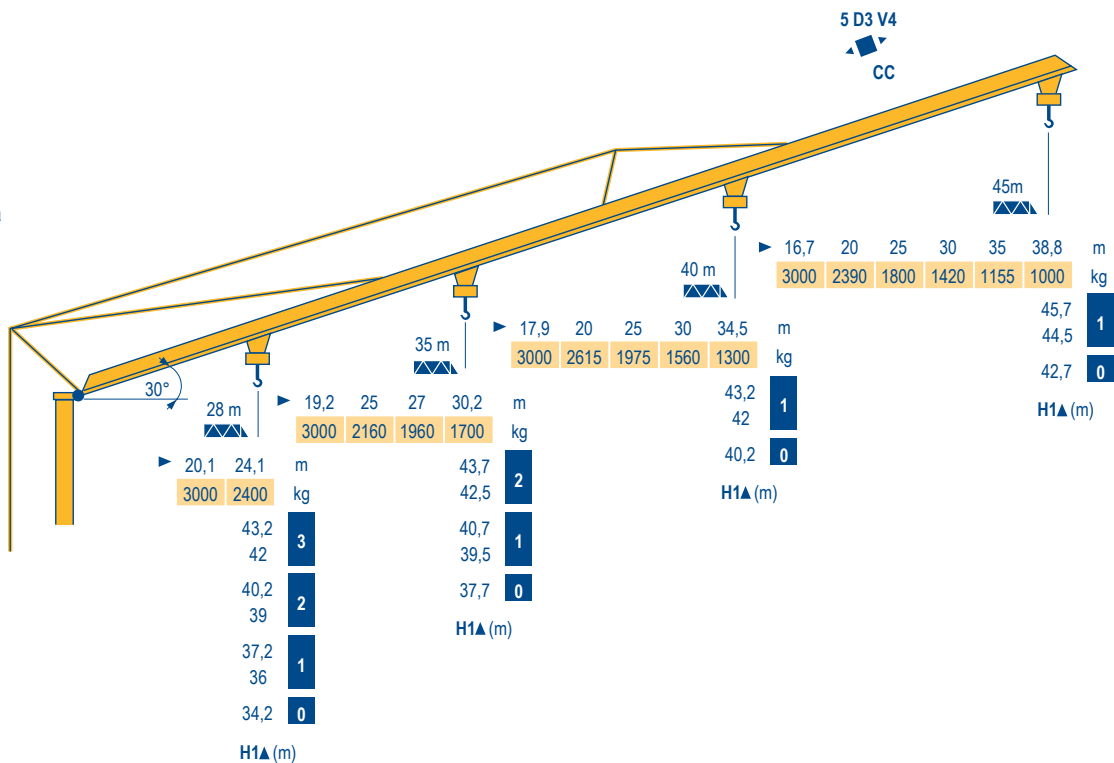

## GTMR 346 B

**POTAIN**



**F**  
Chariot distributeur et courbes de charges  
Réactions en service  
Réactions hors service  
A vide sans lest (ni train de transport) avec flèche et hauteur maximum.

**D**  
Verfahrbare Laufkatze und Lastkurven  
Reaktionskräfte in Betrieb  
Reaktionskräfte außer Betrieb  
Ohne Last, Ballast (und Transportachse), mit Maximalausleger und Maximalhöhe.

**GB**  
Traversing trolley and load diagrams  
Reactions in service  
Reactions out of service  
Without load, ballast (or transport axles), with maximum jib and maximum height.













**E**  
Carro distribuidor y curvas de cargas  
Reacciones en servicio  
Reacciones fuera de servicio  
Sin carga, sin lastre, (ni tren de transporte), flecha y altura máxima.

**I**  
Carrellino distributore e curve di carico  
Reazioni in servizio  
Reazioni fuori servizio  
A vuoto, senza zavorra (ne assali di trasporto) con braccio massimo e altezza massima.

**P**  
Carro distribuidor e curva de cargas  
Reações em serviço  
Reações fora de serviço  
Sem carga (nem trem de transporte)- sem lastro com lança e altura máximas.

Mécanismes  
Antriebe  
Mechanisms  
Mecanismos  
Meccanismi  
Mecanismos

LVE 2

									ch - PS hp	kW
										
	20 LVF 15	m/min	5,5	27,5	55	2,7	13,7	27,5	20	15
		Kg	3000	3000	1500	6000	6000	3000		
	5 D3 V4	m/min	15 - 30 - 58						5,5	4
	RCV 51	tr/min U/min rpm	0 → 0,8						6	4,4
 R ≥ 8 m	TDV 324	m/min	25						2 x 4	2 x 3
	TB 124	m/min	25						2 x 4	2 x 3
CEI 38 			IEC 38			KVA				
400 V (+6% -10%) 50 Hz			30 kVA							





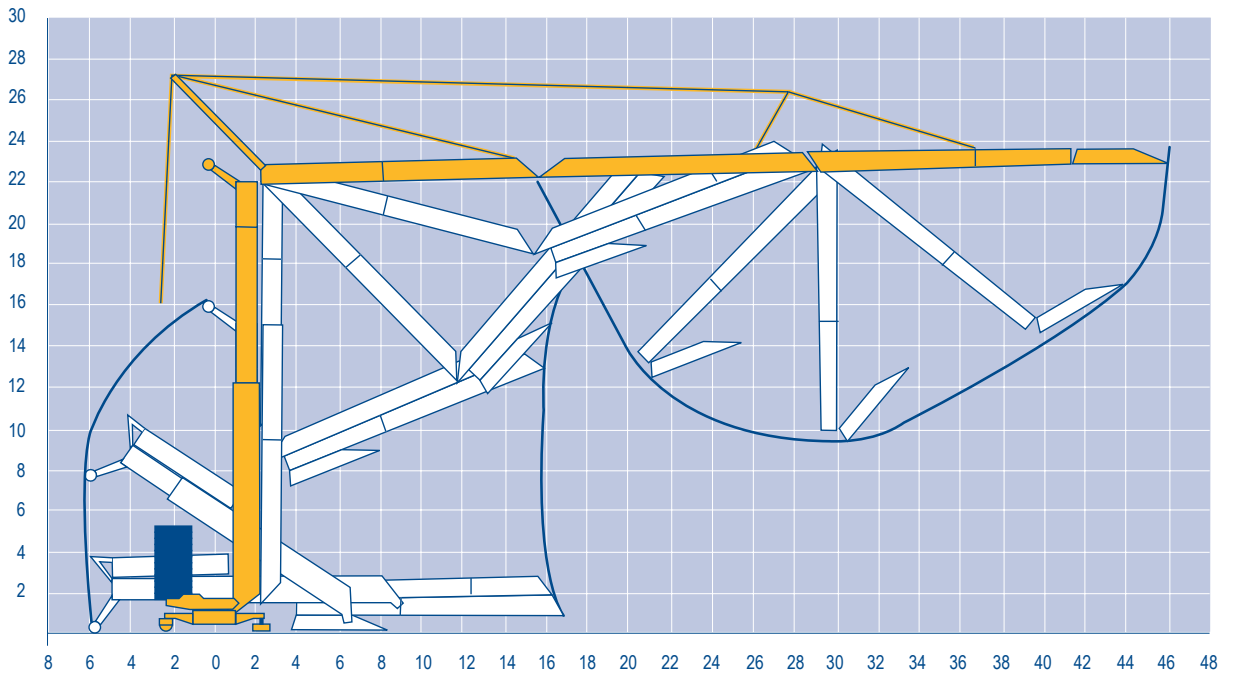











Montage  
Montage  
Erection  
Montaje  
Montaggio  
Montagem

LVE 1



GTMR 346 B

**POTAIN** 

F	D	GB	E	I	P
 Leverage	 Heben	 Hoisting	 Elevación	 Sollevamento	 Elevação
 Distribution	 Katzfahren	 Trolleying	 Distribución	 Distribuzione	 Distribuição
 Orientation	 Schwenken	 Slewing	 Orientación	 Rotazione	 Rotação
 Translation	 Kranfahren	 Travelling	 Traslación	 Traslazione	 Translação

Transport  
 Transport  
 Transport  
 Transporte  
 Trasporto  
 Transporte

LVE 1

DJ126M/S215M

15A/25A

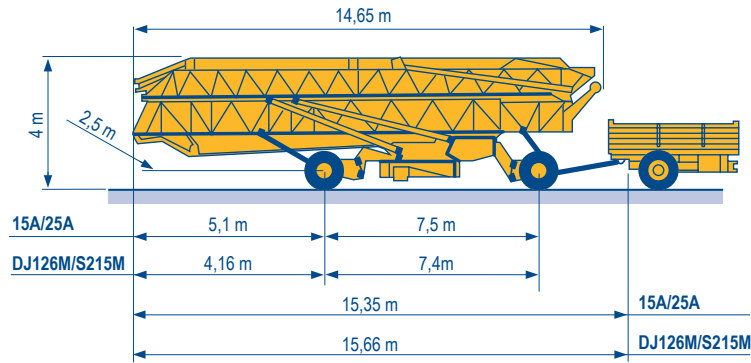

S4/S215M

S5B/J215M

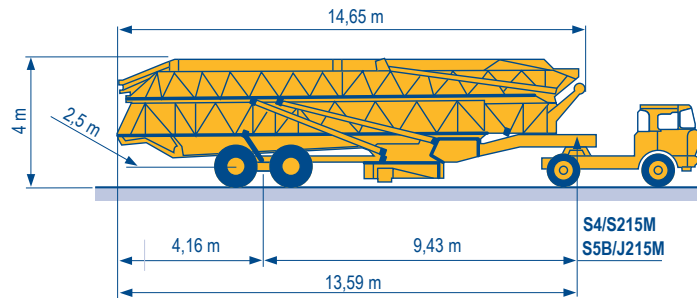

Document commercial non contractuel. Pour toute information technique se référer à la notice correspondante.

Unverbindliches Vertriebsdokument. Für technische Informationen, siehe die entsprechenden Anweisungen.

This commercial document is not legally binding. For any technical information, please refer to the corresponding instructions.

Documento commercial non contractuel. Para cualquier información técnica, ver la noticia correspondiente.

Documento commerciale non vincolante, per tutte le informazioni tecniche fare riferimento al catalogo istruzioni.

Documento comercial não contratual. Para qualquer informação técnica complementar consultar as respectivas instruções.

**Manitowoc**  
 Crane CARE

**POTAIN**   
 Manitowoc Crane Group



**Americas**

Tel : +1 888 479 7278  
 Tel : +1 717 593 2000

**Europe - Middle East - Africa**

Tel : +33 (0) 4 72 81 50 00  
 Tel : +44 (0) 191 522 2000

**Asia - Pacific**

Tel : +65 6264 1188  
 Fax : +65 6862 4040

[www.manitowoccrane.com](http://www.manitowoccrane.com)

18, rue de Charbonnières - B.R.173  
 69132 ECULLY Cedex - France

Tél. : +33 (0) 4 72 18 20 20  
 Fax. : +33 (0) 4 72 18 20 00  
[www.manitowoccrane.com](http://www.manitowoccrane.com)

**GTMR 346 B**

Code G-91985-34\_Réf. 2003 48 LYE 4

Copyright.Reproduction interdite © POTAIN 2003

Réalisation Secloc