

GTMR 336 B

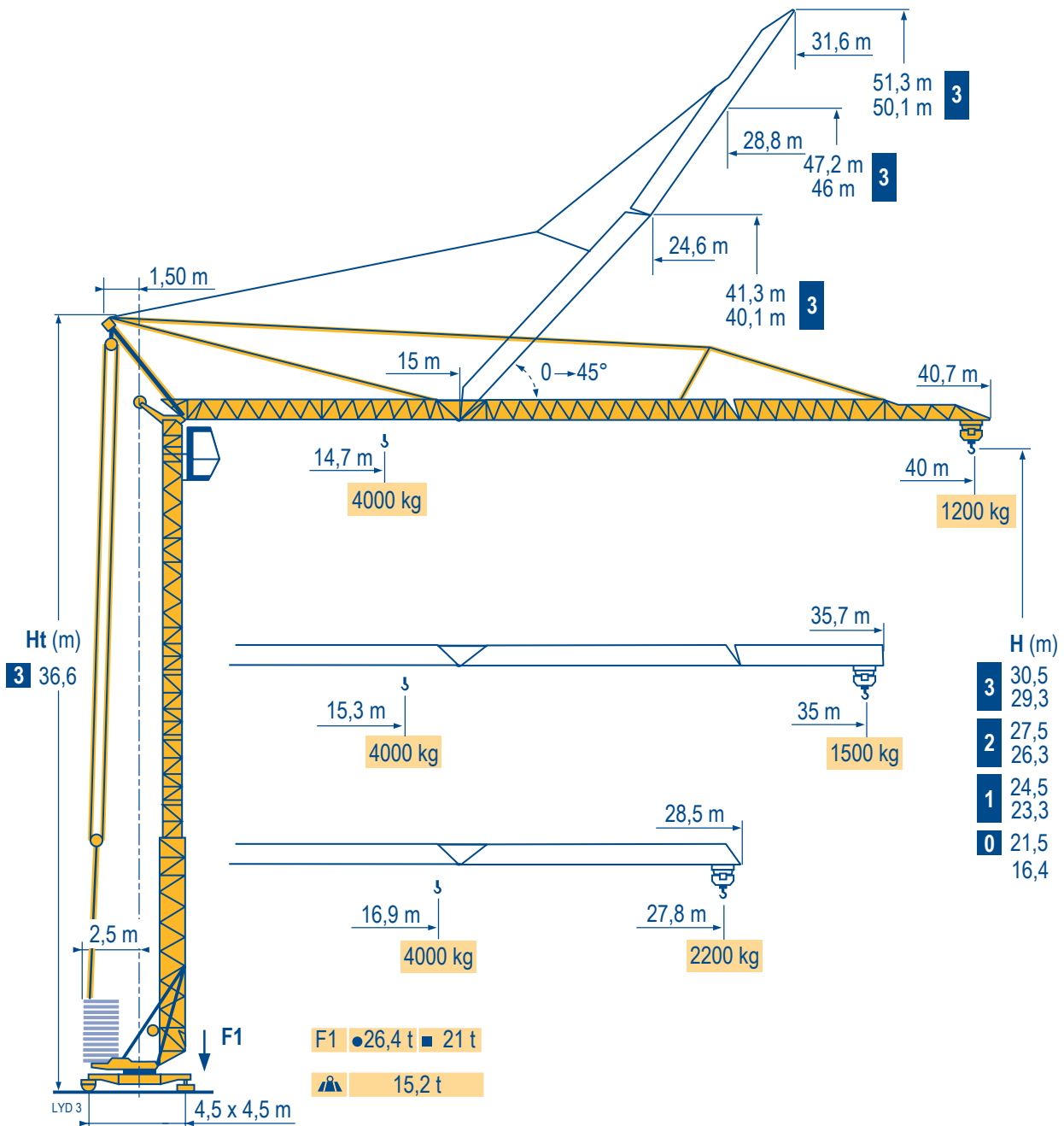

Courbes de charges	40 m	2,8	14,7	16	18	20	22	24	26	26,3	28	30	32	34	36	38	40 m	
Lastkurven			4000	3600	3110	2740	2440	2190	1980	-	1810	1660	1530	1420	1320	1230	1150	kg
Load diagrams										2000	1860	1710	1580	1470	1370	1280	1200	kg
Curvas de cargas	35 m	2,8	15,3	16	18	20	22	24	26	27,6	28	30	32	34	35 m			
Curve di carico			4000	3800	3290	2890	2570	2310	2100	-	1920	1760	1620	1500	1450			kg
Curva de cargas										2000	1970	1810	1670	1550	1500			kg
LVD 1	27,8 m	2,8	16,9	18	20	22	24	26	27,8 m									
			4000	3720	3270	2920	2630	2390	2200									kg
										2000								kg

Flèche relevée
Ausleger in Steilstellung
Luffing jib
Flecha izada
Braccio impennato
Lança inclinada

LVD 1

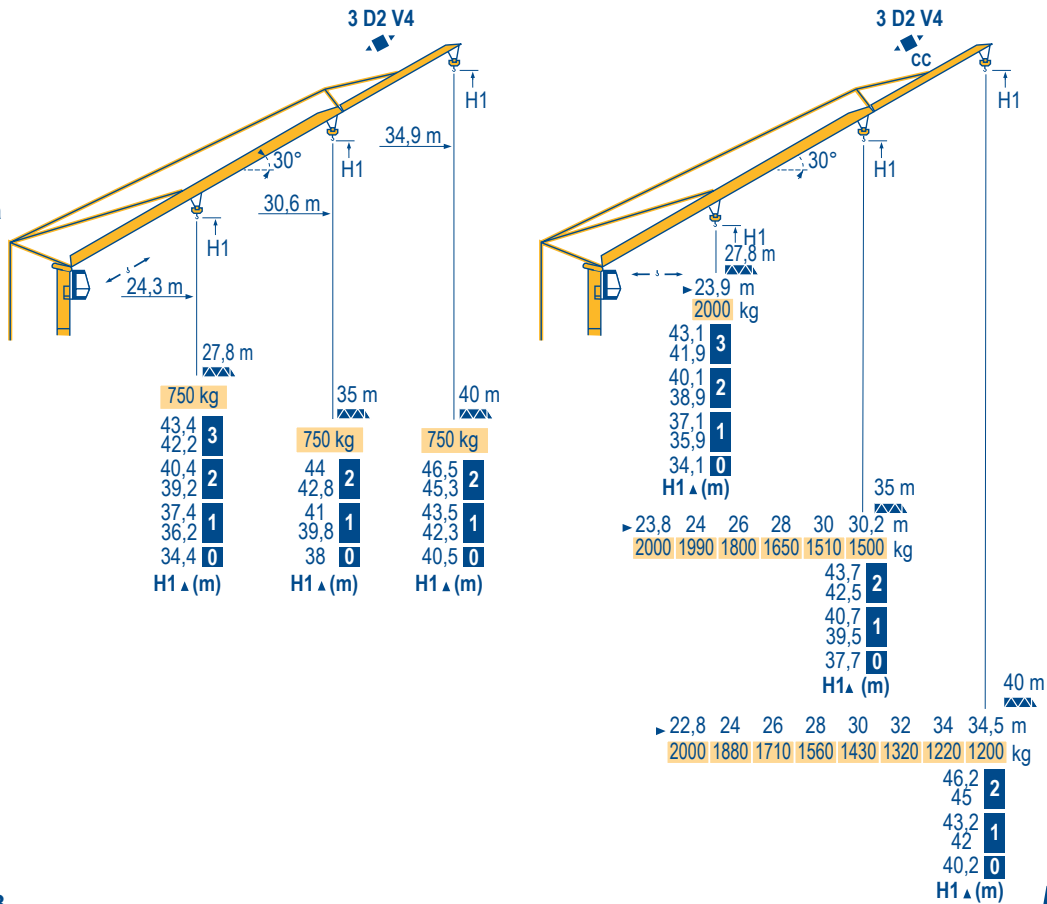















GTMR 336 B

POTAIN

F	D	GB	E	I	P
Chariot distributeur	Verfahrbare Laufkatze	Traversing trolley	Carro distribuidor	Carrellino distributore	Carro distribuidor
Chariot distributeur et courbes de charges	Verfahrbare Laufkatze und Lastkurven	Traversing trolley and load diagrams	Carro distribuidor y curvas de cargas	Carrellino distributore e curve di carico	Carro distribuidor e curva de cargas
Réactions en service	Reaktionskräfte in Betrieb	Reactions in service	Reacciones en servicio	Reazioni in servizio	Reacções em serviço
Réactions hors service	Reaktionskräfte außer Betrieb	Reactions out of service	Reacciones fuera de servicio	Reazioni fuori servizio	Reacções fora de serviço
A vide sans lest (ni train de transport) avec flèche et hauteur maximum.	Ohne Last, Ballast (und Transportachse), mit Maximalausleger und Maximalhöhe.	Without load, ballast (or transport axles), with maximum jib and maximum height.	Sin carga, sin lastre, (ni tren de transporte), flecha y altura máxima.	A vuoto, senza zavorra (ne assali di trasporto) con braccio massimo e altezza massima.	Sem carga (nem trem de transporte)- sem lastro com lança e altura máximas.

Mécanismes
Antriebe
Mechanisms
Mecanismos
Meccanismi
Mecanismos

LYD 2

									ch - PS hp	kW
										
	20 TDPC 10	m/min	8	25	50	4	12,5	25	20	15
		kg	2000	2000	1300	4000	4000	2600		
	20 LVF 10	m/min	5	25	50	2,5	12,5	25	20	15
		kg	2000	2000	1300	4000	4000	2600		
	3 D2 V4	m/min	22 - 44						4	3
	RCV 32	tr/min U/min rpm	0 → 0,8						4	3
 R ≥ 8 m	TVD 122	m/min	25						2 x 2	2 x 1,5
	TB 122	m/min	25						2 x 2	2 x 1,5
CEI 38 			IEC 38			kVA				
400 V (+6% -10%) 50 Hz			25 kVA							

Montage
Montage
Erection
Montaje
Montaggio
Montagem

LYD 1

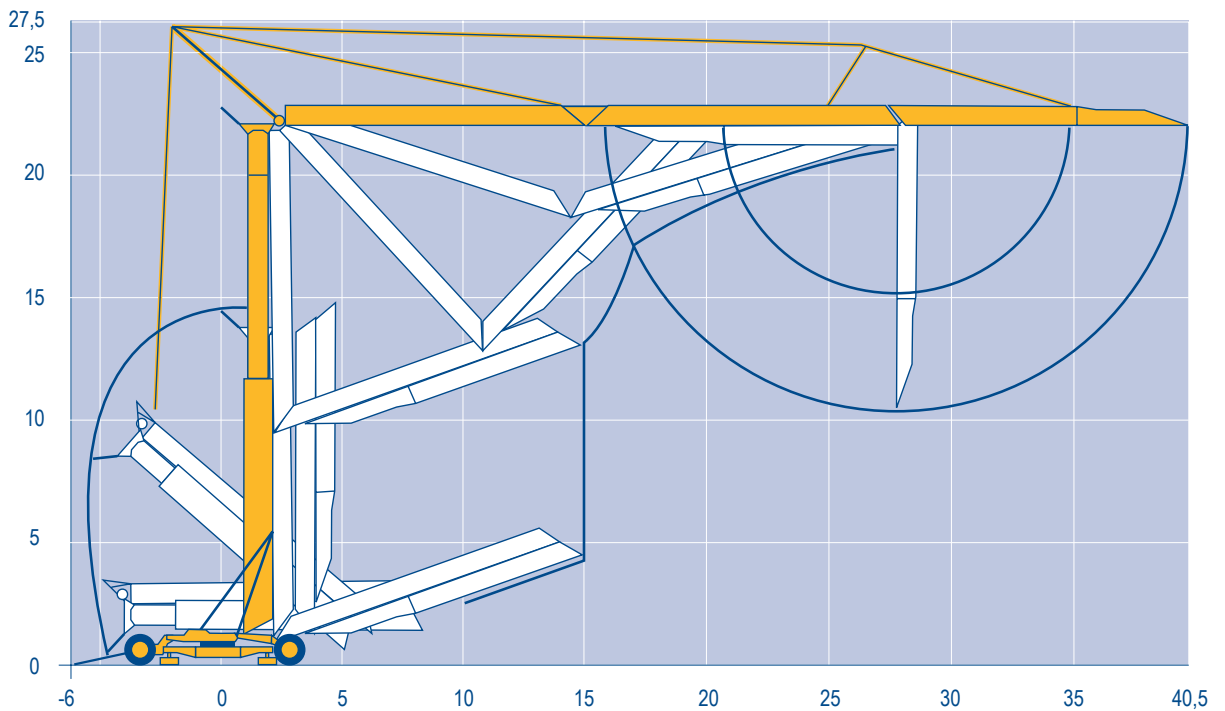

GTMR 336 B

POTAIN 

F	D	GB	E	I	P
 Levage	 Heben	 Hoisting	 Elevación	 Sollevamento	 Elevação
 Distribution	 Katzfahren	 Trolleying	 Distribución	 Distribuzione	 Distribuição
 Orientation	 Schwenken	 Slewing	 Orientación	 Rotazione	 Rotação
 Translation	 Kranfahren	 Travelling	 Traslación	 Traslazione	 Translação

Transport
 Transport
 Transport
 Transporte
 Trasporto
 Transporte

LYD 1

15A/25A

DJ126M/S215M

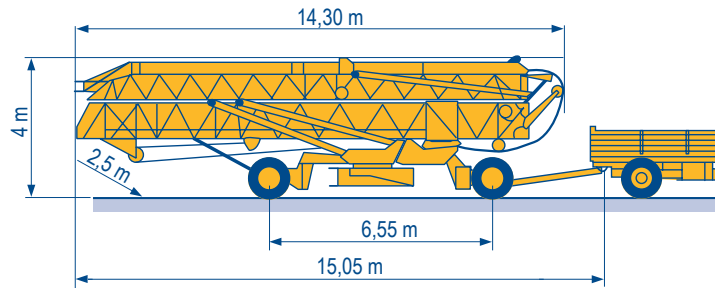

S4/S215M

S5B/J215M

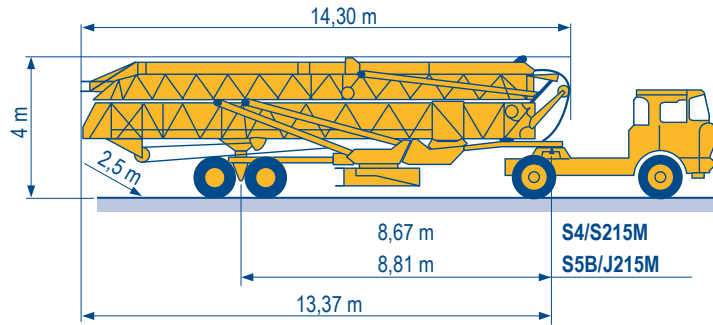

Document commercial non contractuel. Pour toute information technique se référer à la notice correspondante.

Unverbindliches Vertriebsdokument. Für technische Informationen, siehe die entsprechenden Anweisungen.

This commercial document is not legally binding. For any technical information, please refer to the corresponding instructions.

Documento commercial non contractuel. Para cualquier información técnica, ver la noticia correspondiente.

Documento commerciale non vincolante, per tutte le informazioni tecniche fare riferimento al catalogo istruzioni.

Documento comercial não contratual. Para qualquer informação técnica complementar consultar as respectivas instruções.



Americas
 Tel : +1 888 479 7278
 Tel : +1 717 593 2000

Europe - Middle East - Africa
 Tel : +33 (0) 4 72 81 50 00
 Tel : +44 (0) 191 522 2000

Asia - Pacific
 Tel : +65 6264 1188
 Fax : +65 6862 4040

www.manitowoccrane.com

18, rue de Charbonnières - B.R.173
 69132 ECULLY Cedex - France

Tél. : +33 (0) 4 72 18 20 20
 Fax. : +33 (0) 4 72 18 20 00
 www.manitowoccrane.com

GTMR 336 B

Code F-91985-33_Réf. 2003 48 LYD 4

Copyright.Reproduction interdite © POTAIN 2003

Réalisation Secloc